

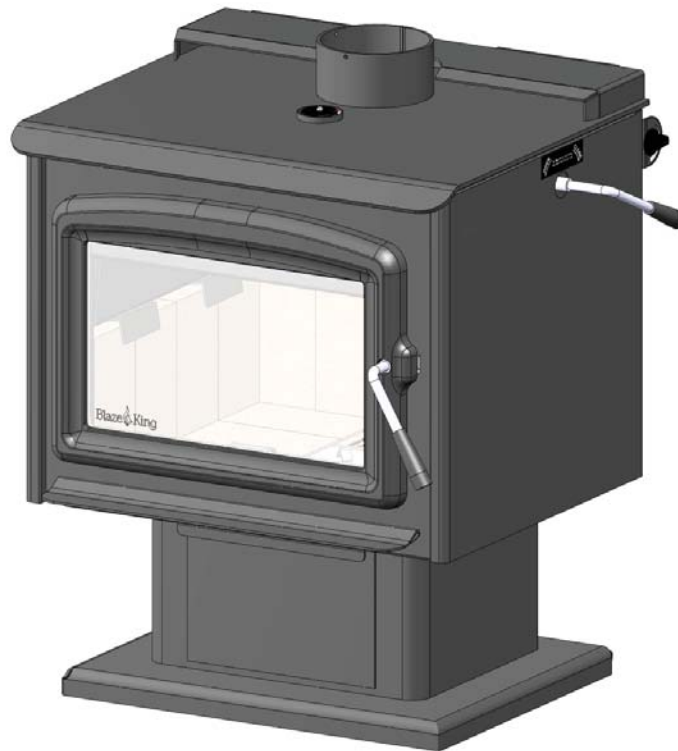

# **SIROCCO SC30L.NZ(Leg) & SC30P.NZ(Pedestal)**

## **SOLID FUEL WOOD CATALYTIC STOVE**



Your local building authority should be consulted before installation to determine the need to obtain a permit.

## **OPERATION & INSTALLATION MANUAL**

### **Manufactured By**

**Valley Comfort Systems Inc.**, 1290 Commercial Way, Penticton, BC, V2A 3H5, Canada  
Phone: 250-493-7444 ♦ Fax: 250-493-5833 ♦ [www.blazeking.com](http://www.blazeking.com) ♦ [info@blazeking.com](mailto:info@blazeking.com)

### **Distributed By**

**Pellet Fire Solutions Ltd.**, P/O Box 11-245, Sockburn  
Christchurch, New Zealand  
[www.pelletfiresolutions.co.nz](http://www.pelletfiresolutions.co.nz)

**⚠ WARNING**

- BEFORE INSTALLING THIS APPLIANCE, CONTACT THE LOCAL BUILDING OR FIRE OR OTHER AUTHORITY HAVING JURISDICTION AND FOLLOW THEIR GUIDELINES.
- THIS APPLIANCE MUST BE INSTALLED BY A QUALIFIED INSTALLER. FOLLOW THE INSTALLATION DIRECTIONS. DO NOT OPERATE WITHOUT FULLY ASSEMBLING ALL COMPONENTS.
- IF THIS APPLIANCE IS NOT PROPERLY INSTALLED, A HOUSE FIRE MAY RESULT.
- THIS APPLIANCE IS HOT WHEN OPERATED AND CAN CAUSE SEVERE BURNS IF CONTACTED. CHILDREN AND PETS MUST BE KEPT FROM TOUCHING THE APPLIANCE WHEN IT IS HOT.
- COMBUSTIBLE MATERIAL SUCH AS FIRE WOOD, WET CLOTHING, ETC. PLACED TOO CLOSE CAN CATCH FIRE. OBJECTS PLACED IN FRONT OF THE APPLIANCE MUST BE KEPT A MINIMUM OF 48" (1219 MM) FROM THE FRONT OF THE APPLIANCE.

**Blaze King grants no warranty, implied or stated, for the installation or maintenance of the appliance and assumes no responsibility of any consequential damage(s).**

**PARTS INCLUDED WITH THE SIROCCO**

- |   |
|---|
| 1. Poker                                      |
| 2. Manual Kit (w/ thermometer, bypass handle) |

**OPTIONAL EQUIPMENT**

- |                          |                              |
|--------------------------|------------------------------|
| 1. Convection Deck Z3915 | 2. Leg Model Ash Pan (Z3820) |
|--------------------------|------------------------------|

**FLOOR PROTECTION**

If the stove sits on a combustible floor, a non-combustible shield must be used underneath the stove and extending 300 mm from the front of the fuel-loading opening to the edge of the floor protector, and 200 mm from each side of the fuel-loading opening.

See the next page for minimum sizes depending on model. This floor protection is required to prevent sparks from falling onto the combustible floor.

**THIS PRODUCT DOES NOT REQUIRE THERMAL HEARTH PAD PROTECTION.**

**INITIAL INSTALLATION**

The Blaze King Sirocco was tested to AS/NZS 2918:2001 Appendix B, using a Davins Flue Kit (Kit Code 2074) under Safe Clearance Test Report SL0478 by Spectrum Laboratories. The Davins Flue Kit 2074 was tested to AS/NZS 2918:2001 Appendix F by Applied Research under Test Report ARS 04/969R1. It is Blaze Kings recommendation that the Sirocco is installed as per these instructions, and that a flue height of a minimum 4.6 m from the top of the unit is achieved. It is the responsibility of the installer to ensure that the installation of this flue complies with AS/NZS 2918:2001. All relevant building codes must be adhered to.

**⚠ WARNING**

- **THE APPLIANCE AND FLUE-SYSTEM SHALL BE INSTALLED IN ACCORDANCE WITH AS/NZS 2918 AND THE APPROPRIATE REQUIREMENTS OF THE RELEVANT BUILDING CODE OR CODES.**
- **APPLIANCES INSTALLED IN ACCORDANCE WITH THIS STANDARD SHALL COMPLY WITH THE REQUIREMENTS OF AS/NZS 4013 WHERE REQUIRED BY THE REGULATORY AUTHORITY, I.E. THE APPLIANCE SHALL BE IDENTIFIABLE BY A COMPLIANCE PLATE WITH THE MARKING 'TESTED TO AS/NZS 4013'.  
ANY MODIFICATION OF THE APPLIANCE THAT HAS NOT BEEN APPROVED IN WRITING BY THE TESTING AUTHORITY IS CONSIDERED TO BE IN BREACH OF THE APPROVAL GRANTED FOR COMPLIANCE WITH AS/NZS 4013.**

**⚠ CAUTION**

- **MIXING OF APPLIANCE OR FLUE-SYSTEM COMPONENTS FROM DIFFERENT SOURCES OR MODIFYING THE DIMENSIONAL SPECIFICATION OF COMPONENTS MAY RESULT IN HAZARDOUS CONDITIONS. WHERE SUCH ACTION IS CONSIDERED, THE MANUFACTURER SHOULD BE CONSULTED IN THE FIRST INSTANCE.**
- **CRACKED AND BROKEN COMPONENTS, e.g. GLASS PANELS OR CERAMIC TILES, MAY RENDER THE INSTALLATION UNSAFE.**

**INSTALLATION INSTRUCTIONS:**

1. Locate fire on a non combustible hearth, ensuring minimum clearances are obtained to combustibles, be it a flat wall or corner installation. (see "MINIMUM CLEARANCES")
2. Mark a centre point on the ceiling that is directly above the centre of the flue outlet. It is recommended that a laser or plumb bob is used in this instance.
3. After drilling a smaller 6 mm hole at this point, check in ceiling cavity that all clearances to the 250 mm outer flue will be achieved at this point. Please ensure that no major timber or steel supports are cut or removed.
4. Once confirmation that positioning of the fire is correct, continue to cut a 250 mm square hole out. This hole can be cut out further if preferred. Continue to fit timber or steel supports that will support 250 mm outer casing.
5. Position the 250 mm outer flue casing, so that it sits flush with the underside of the ceiling.
6. Support the outer casing at this point. Continue to run the outer casing up through the roof cladding. Ensure that all minimum heights are achieved to comply with AS/NZS 2918:2001. Note that Blaze King recommend a minimum height of 4.6 m of flue from the top of the fire. Add any additional support to the outer casing.
7. Continue to fit an appropriate flashing to seal off the roofing material. Also fit support stays if more than 1.2 m of flue is above the roofline.
8. Continue with installing the 150 mm inner flues. Each join needs to be sealed with Maniseal, or some other form of exhaust cement. Each join needs to be secured with 3 stainless rivets or self-tapping screws. The 150 mm inner flue needs to be sealed and secured to the fire.

9. Continue then to install the 200 mm inner casing. With the use of the combination liner system, the brackets on the 200 mm inner liner should position this liner correctly. Ensure that the 200 mm inner liner protrudes 200 mm above the roof line.
10. Then continue to fit ceiling plate, ensuring that an even distance is created between the inner flue and the hole in the ceiling plate. The stand-offs formed in this ceiling plate will ensure a 12mm gap for air flow is obtained.
11. Fit 1001 Flue Reflector. Please note that this is only required if there is a combustible wall within the vicinity of the fire.
12. Ensure that seismic restraint is fitted to the fire. (see below)
13. Finally, fit the ADD Rain Cap to the top of the flue. The application of a 250mm Galv Slip Liner, should eliminate the need for any cutting of flue. Please note that the recommendation of the ADD Cowl is preferred, but not restricted to this Cowl.

## SEISMIC RESTRAINT

**NOTE: THE FIRE MUST BE SECURELY FASTENED TO THE FLOOR AS A SEISMIC RESTRAINT.** For the pedestal model SC30P.NZ, remove the ash drawer to access the screw down holes (see cut away image below). For the leg model SC30L.NZ, use the LEG ANCHOR KIT #S.ZR8039 to secure fire to the floor.

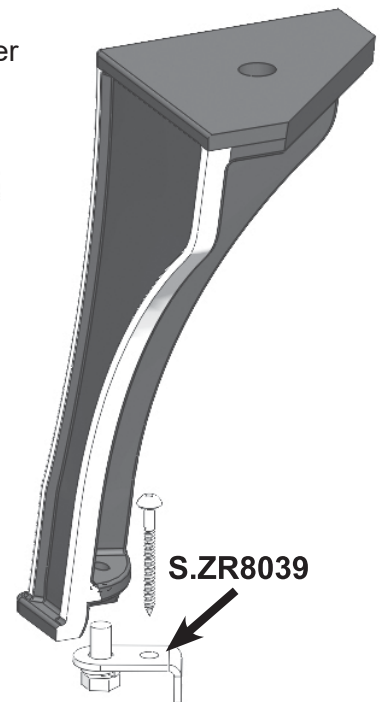
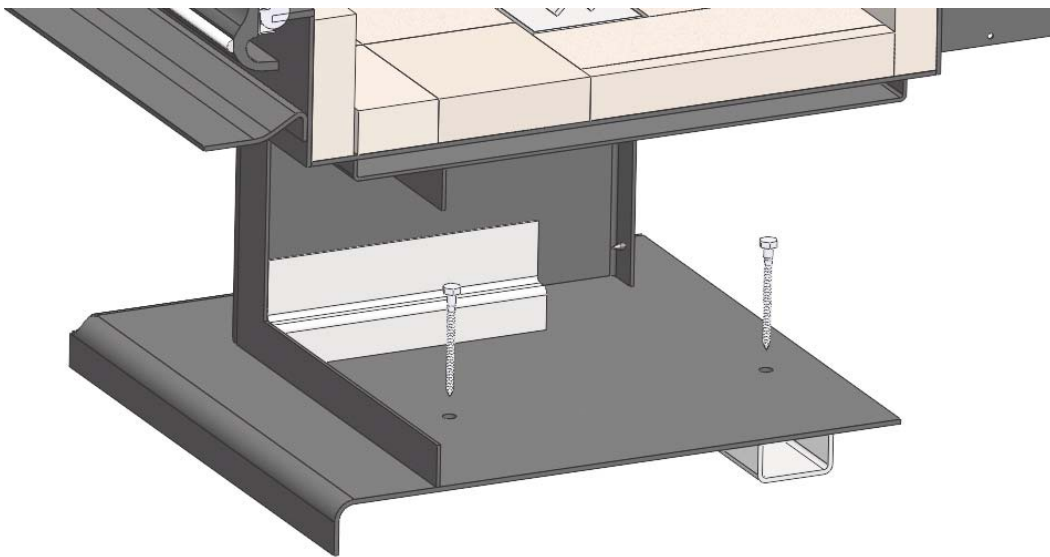

**MINIMUM CLEARANCES**

Parallel Position Clearance Distance	Position	Clearance (mm)
	(A) Rear	320
	(B) Side	320
	(C) Floor protector (front)	300
	(D) Floor protector (side)	200
	(E) Flue (rear)	480

Corner Position Clearance Distance	Position	Clearance (mm)
	(F) Side	200
	(G) Side	200
	(H) Floor protector (front)	300
	(I) Floor protector (side)	200
	(J) Flue (rear)	560
	(K) Flue (corner)	792

## STANDARD FLUE INSTALLATION Davins Flue Kit (Kit Code 2074)

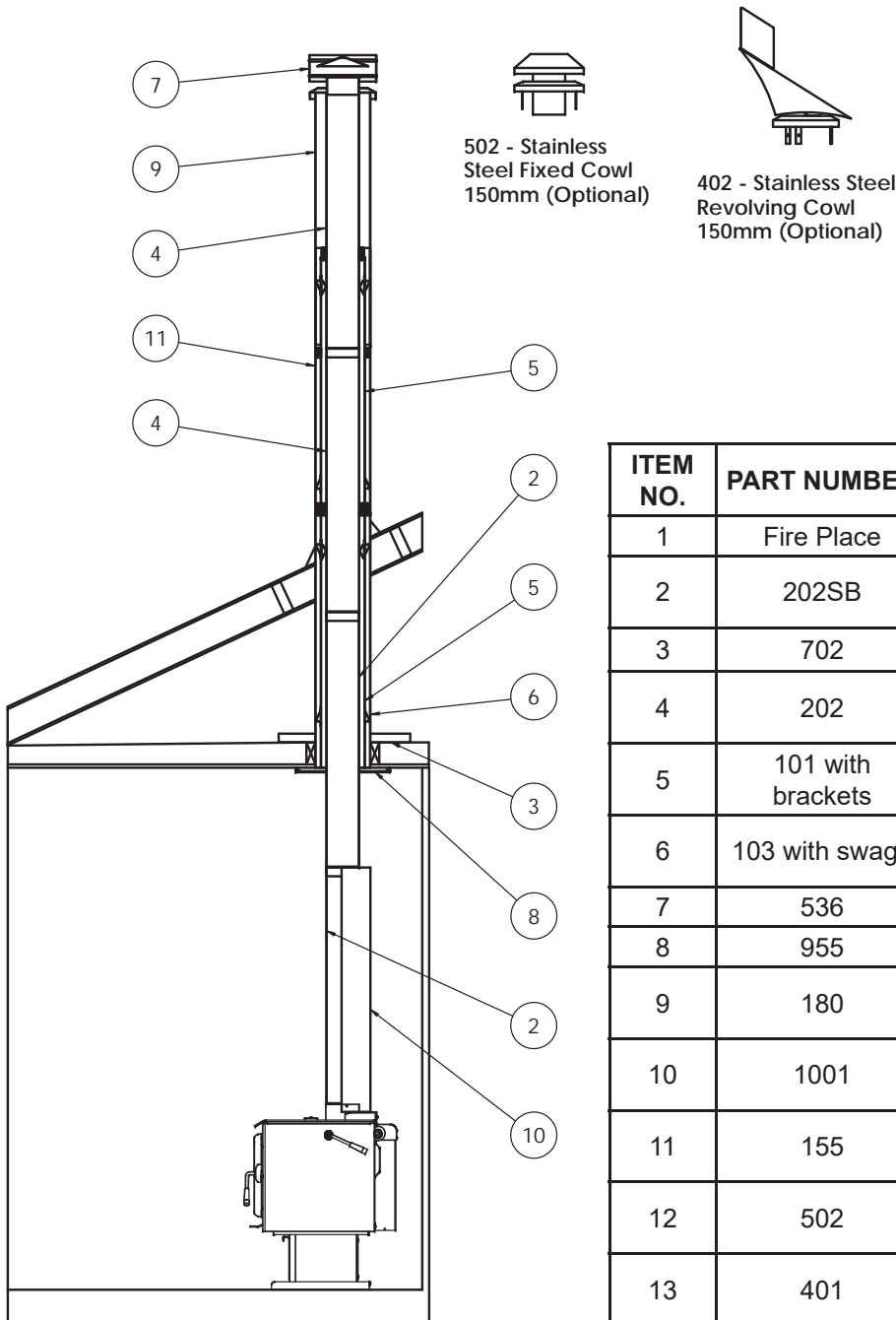

ITEM NO.	PART NUMBER	DESCRIPTION	QTY.
1	Fire Place	Stand-alone Fire Place	1
2	202SB	150mm x 1200mm Satin Black Flue	2
3	702	Mounting Rail (950mm)	2
4	202	150mm x 1200mm Stainless Steel Flue	2
5	101 with brackets	200mm x 1200mm Galvanised Steel liner with brackets	2
6	103 with swage	250mm x 1200mm Galvanised Steel liner with swage	1
7	536	Fixed ADD Stainless Steel Cowl	1
8	955	430 x 430 Ceiling Plate	1
9	180	253mm x 1200mm Galvanised Slip liner	1
10	1001	150mm Matt Black Flue Reflector	1
11	155	250mm x 1200 Galvanised Liner with swage	1
12	502	150mm Stainless Steel Fixed Cowl	X
13	401	150mm Stainless Steel Revolving Cowl	X

**COMBUSTION AIR**

Ensure adequate combustion air allowing for all other exhausting type appliances in the dwelling (range hoods, dryers, etc.). In air tight homes and modern constructions, careful considerations must be taken into account when using a wood burning appliance. Heat recovery ventilators (HRV) systems along with constant running pan motors in air handlers must be taken into account when balancing the system. Failure to do so may result in air starvation, smoke spillage and carbon monoxide threats. Consult a HVAC specialist for proper installation. Ensure adequate combustion air allowing for all other exhausting type appliances in the dwelling (range hoods, dryers, etc.).

**DRAFTING PERFORMANCE**

Draft is the force which moves air from the appliance up through the chimney. The amount of draft in your chimney depends on the length of the chimney, local geography, nearby obstructions and other factors. External forces, such as wind, barometric pressure, topography, or factors of the home (negative pressure from exhaust fans, chimneys, air infiltration, etc) may adversely affect draft.

Too much draft may cause excessive temperatures in the appliance and may damage the heater. An uncontrollable burn or excessive temperature indicates excessive draft.

Inadequate draft may cause back puffing into the room and 'plugging' of the chimney. Inadequate draft will cause the appliance to leak smoke into the room through appliance and chimney connector joints. Blaze King cannot be responsible for external forces leading to less than optimal performance.

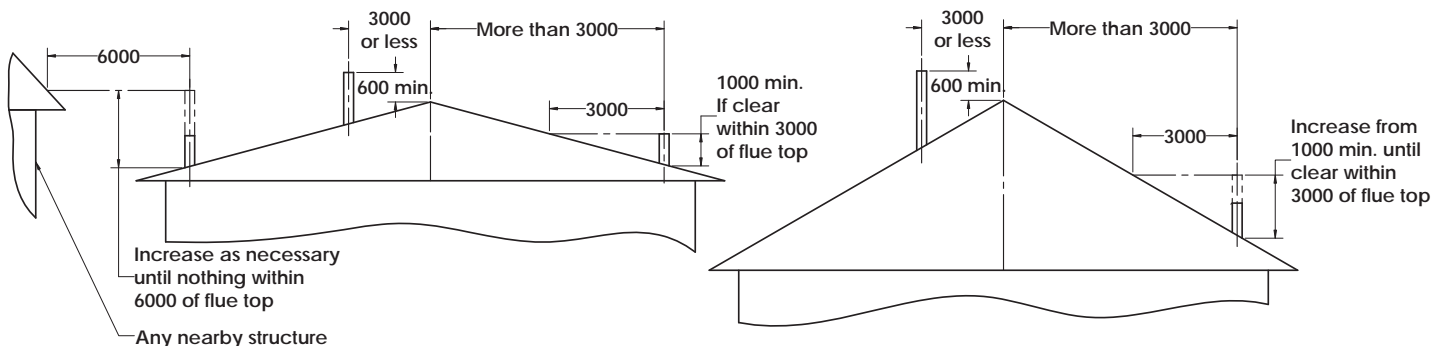
**MINIMUM FLUE HEIGHTS****ROLE OF THE CHIMNEY**

Without a proper installed chimney, this appliance will not burn correctly.

The role of the chimney is to pull the proper amount of air into the firebox for the purpose of complete combustion. Incomplete combustion will lead to more smoke and pollution of the outside air. A proper operating chimney will allow the user to enjoy peak performance at all burn operating levels from low to high. Blaze King therefore recommends vertical installations with a minimum length of 4.6 m from stove top to chimney cap. In all freestanding stove installations, use double wall stove pipe from the stove top to the ceiling support box. The use of double wall stove pipe does allow for reduced clearances, however most importantly, it helps to keep the chimney warm and improve draft.